

Aerodynamic Modelling, Simulation and Control Design for Fantail UAV: with Singapore Technologies Dynamics

Dr Hugh Stone

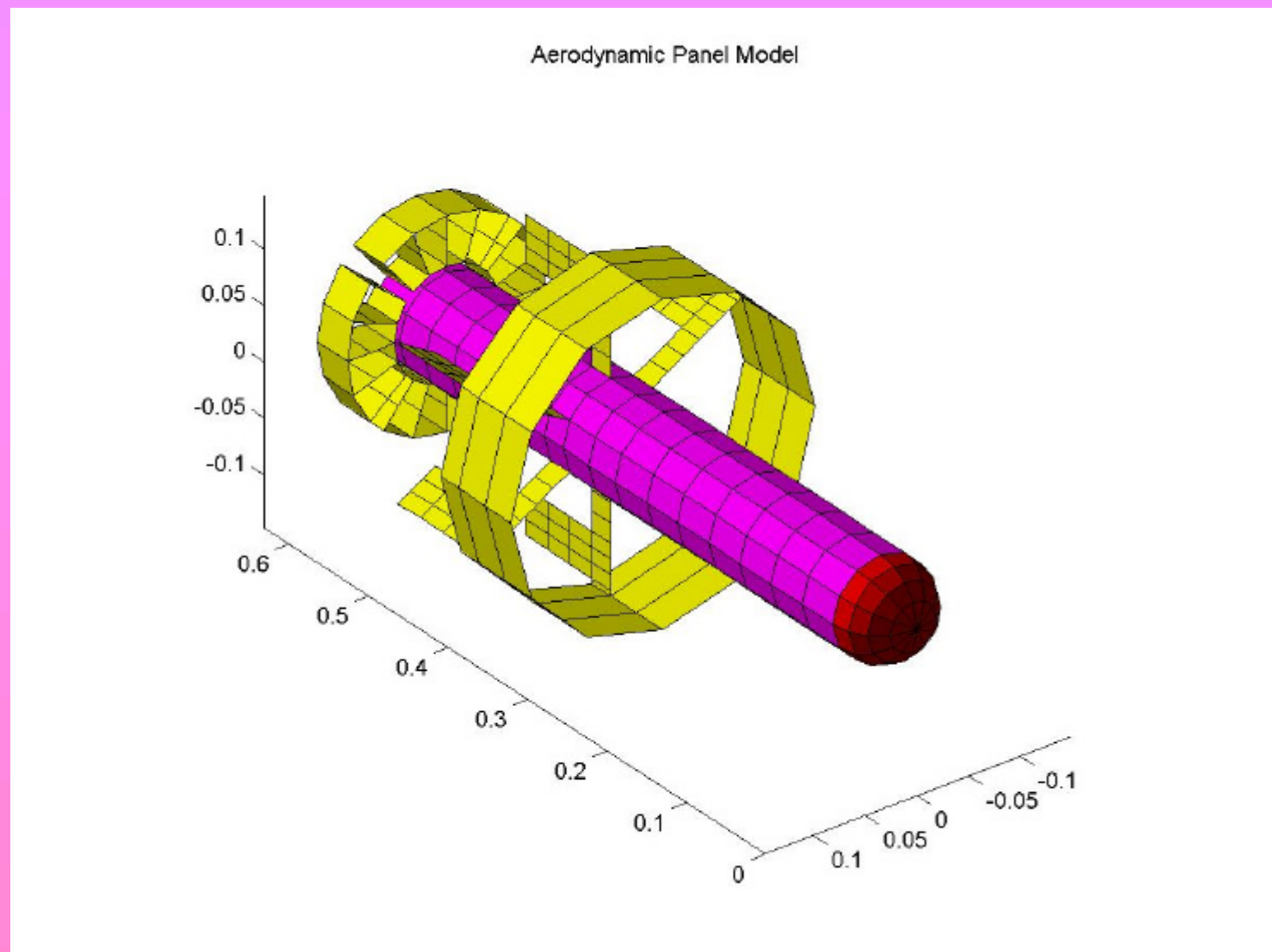

Aerodynamic Panel Model

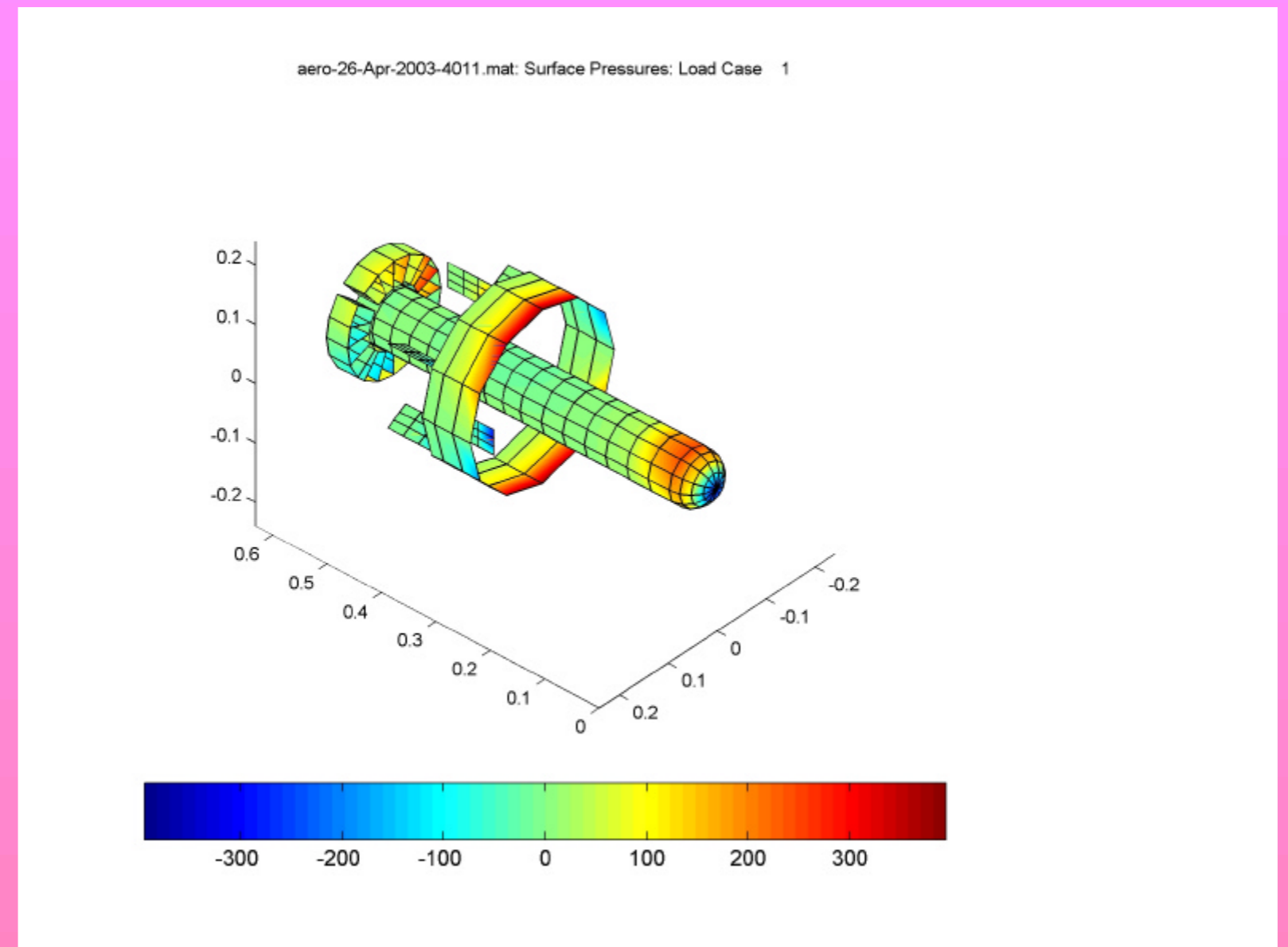

Pressure Field: Horizontal Flight

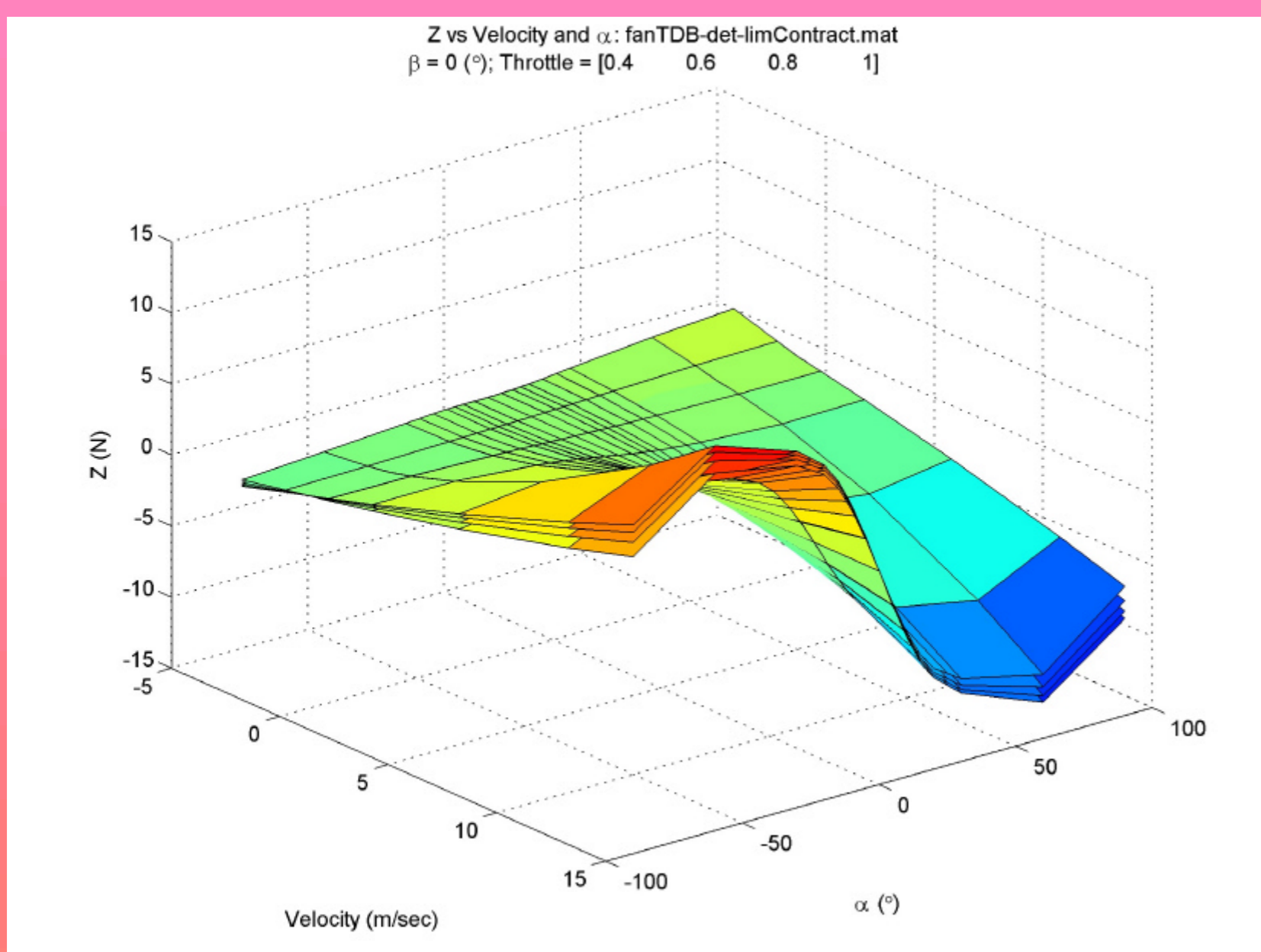

Low-Speed Aerodynamic Database: Z -Force vs V, α

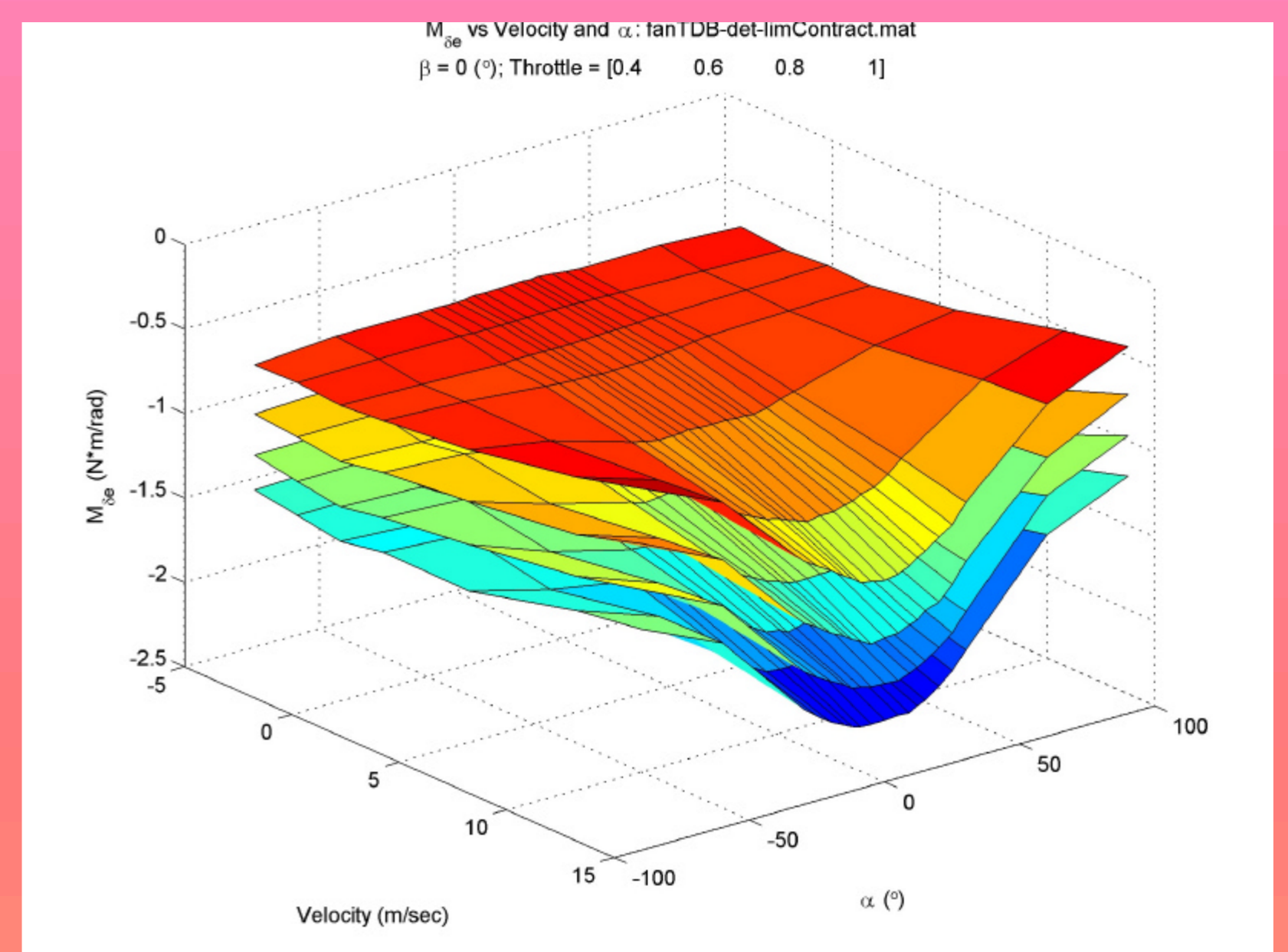

Low-Speed Aerodynamic Database: M_{δ_e} -Moment vs V, α

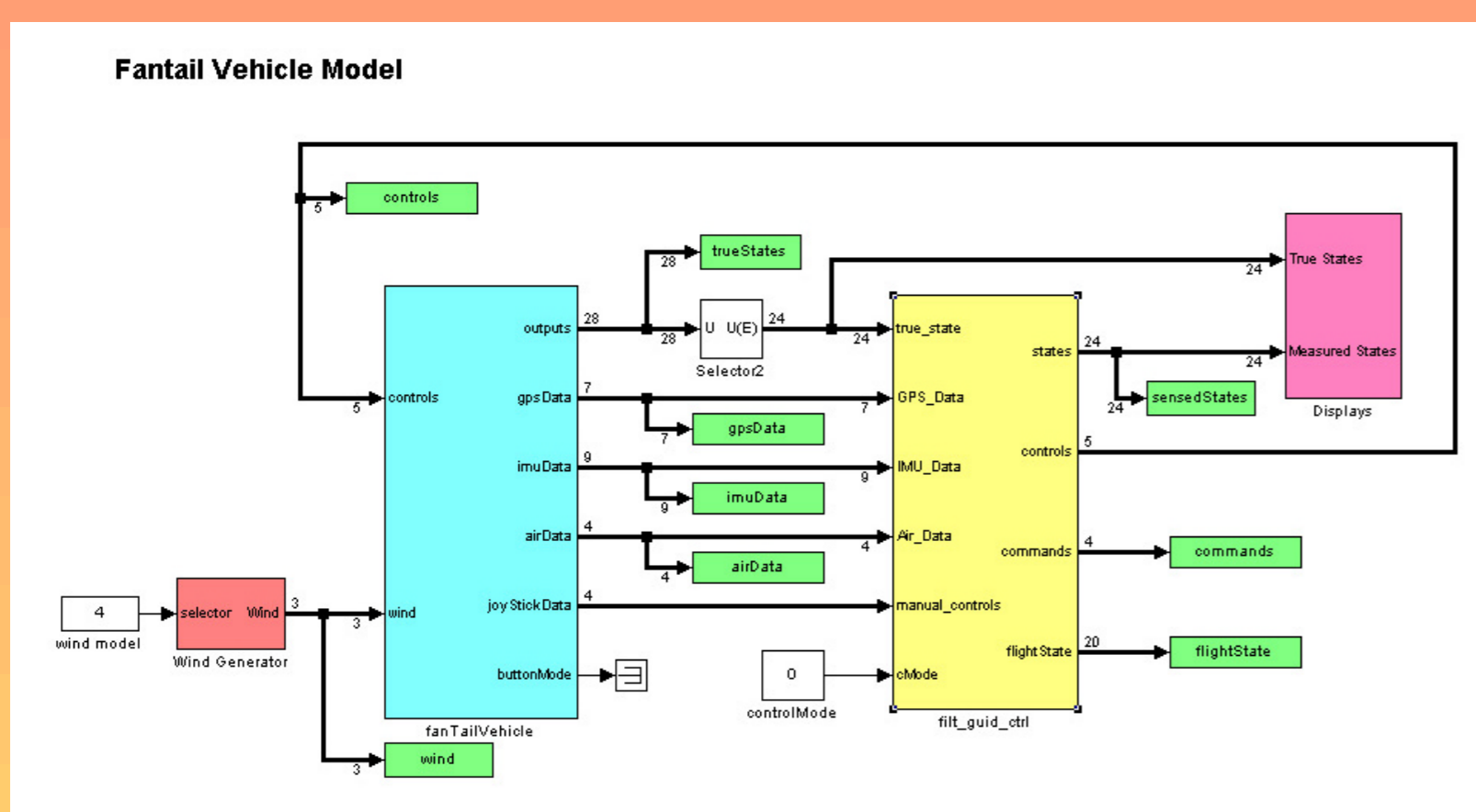

Fantail Full 6-DOF Non-linear Simulation, with Sensor Errors, Wind etc.,.

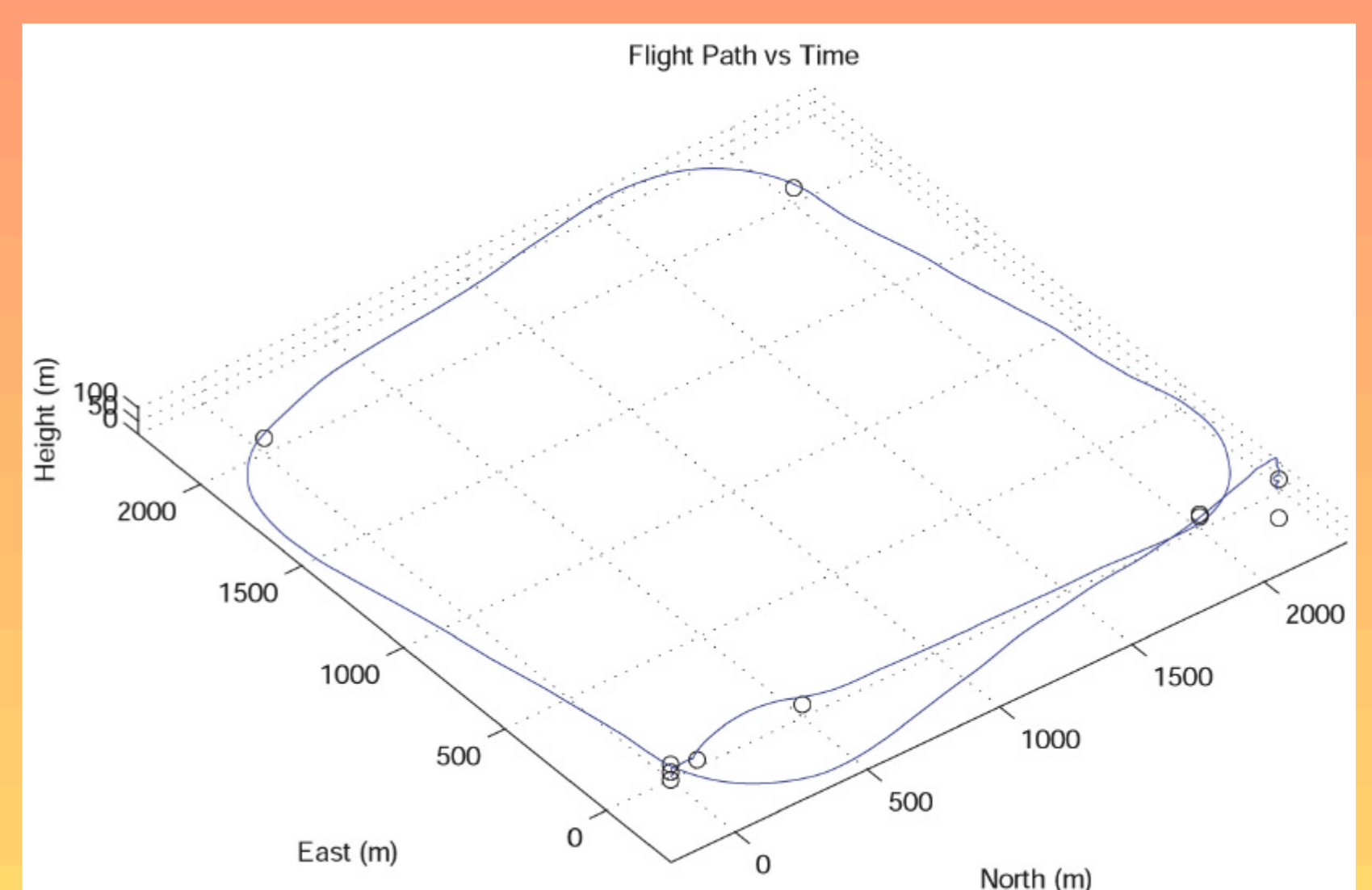

Simulated Flight Path Including Vertical-Horizontal and Horizontal-Vertical Transitions